

RESOLUTION 2022-89

RESOLUTION APPROVING THE SITE PLAN FOR LOT 1, HERITAGE HILL, WEST BRANCH, IOWA.

WHEREAS, BBCO, LLC and the City of West Branch (“BBCO”), are the owners of Lot 1, Heritage Hill, West Branch, Iowa (the “Property”); and

WHEREAS, the City and BBCO previously entered into a Development Agreement whereby the City would convey the City’s portion of Lot 1 to BBCO; and

WHEREAS, BBCO has submitted a proposed Site Plan for the Property; and

WHEREAS, the Planning and Zoning Commission has reviewed said Site Plan and recommended approval of the same; and

WHEREAS, said Site Plan complies with the requirements of Chapter 167 of the Code of Ordinances of the City of West Branch.

NOW, THEREFORE, BE IT RESOLVED, by the City Council of the City of West Branch, Cedar County, Iowa, that the site plan of BBCO for Lot 1, Heritage Hill, West Branch, Iowa, is hereby approved, subject to implementing any changes recommended by the committee reviewing the site plan.

Passed and approved this 3rd day of October, 2022.

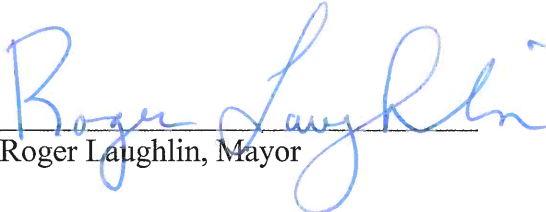

Roger Laughlin, Mayor

ATTEST:



Leslie Brick, City Clerk



ONE ENGINEERS
LAND PLANNERS
LAND SURVEYORS
LANDSCAPE ARCHITECTS
ENVIRONMENTAL SPECIALISTS

1875 S. CALVERT ST.
IOWA CITY, IA 52242
WWW.MMSCONSULTANTS.COM

Prepared By: JAC
Checked By: JAC
Date: 08-24-22

SITE PLAN HERITAGE HILL - LOT 1 WEST BRANCH, IOWA

APPLICANT:
MMS CONSULTANTS INC
1875 S. CALVERT ST.
IOWA CITY, IA 52242

APPLICANT'S ATTORNEY:
JAMES G. HUBBARD
1000 13TH ST. SE
WEST LIBERTY, IOWA 52775

PLAT PREPARED BY:
MMS CONSULTANTS INC
1875 S. CALVERT ST.
IOWA CITY, IA 52242

PAVING CONSTRUCTION NOTES

- PAVEMENT CONSTRUCTION SHALL BE IN ACCORDANCE WITH LOCAL JURISDICTION
- SEWER LINES SHALL BE CONCRETE WITH 18" DIA. MANHOLE SPACING
- PAVEMENT JOINTS SHALL CONFORM TO LOCAL STANDARD ROAD PLAN PRACTICE
- SEWERAGE UNDER IMPROVED PAVEMENT SHALL BE CONSTRUCTED TO THE STANDARD DEPTH OF 18" TO 24" BELOW FINISHED GRADE UNLESS OTHERWISE SPECIFIED
- ALL MANHOLE PAVEMENT SHALL BE 4" CONC.

STANDARD LEGEND AND NOTES

PROPERTY LINE
EXISTING LOT LINES
EXISTING EASEMENTS
EXISTING UTILITY LINES
EXISTING DRIVEWAYS
EXISTING SIDEWALKS
EXISTING CURBS
EXISTING DRIVEWAYS
EXISTING SIDEWALKS
EXISTING CURBS
EXISTING DRIVEWAYS
EXISTING SIDEWALKS
EXISTING CURBS

FINISHING FEATURES AND DEMOLITION

C120 OVERALL SITE LAYOUT AND DIMENSION PLAN
C121 PLAN - NORTH HALF
C122 PLAN - SOUTH HALF
C140 GRADING AND EROSION CONTROL PLAN AND
C141 DETAILED GRADING PLAN - NORTH HALF
C142 DETAILED GRADING PLAN - SOUTH HALF
C180 UTILITY PLAN - SANITARY AND WATER
C181 UTILITY PLAN - STORM AND ELECTRIC
C182 GENERAL NOTES AND DETAILS
C183 LANDSCAPE PLAN
L100

FINISHING FEATURES AND DEMOLITION

7" PCC
6" PCC
4" PCC

ALL FINISHING SHALL BE IN ACCORDANCE WITH LOCAL JURISDICTION

ATTENTION:
ALL FINISHING SHALL BE IN ACCORDANCE WITH LOCAL JURISDICTION

NOTICE:
THIS PLAN IS THE PROPERTY OF MMS CONSULTANTS, INC. AND IS NOT TO BE REPRODUCED OR TRANSMITTED IN ANY FORM OR BY ANY MEANS, ELECTRONIC OR MECHANICAL, WITHOUT THE WRITTEN PERMISSION OF MMS CONSULTANTS, INC.

REVISIONS:

NO.	DATE	DESCRIPTION
1	08-24-22	ISSUED FOR PERMIT

SCALE:
AS SHOWN

DATE:
08-24-22

PROJECT:
HERITAGE HILL - LOT 1

LOCATION:
WEST BRANCH, IOWA

CLIENT:
MMS CONSULTANTS, INC.

DESIGNED BY:
JAC

CHECKED BY:
JAC

DATE:
08-24-22

PROJECT NO.:
C122

SHEET NO.:
11186-002

TOTAL SHEETS:
1

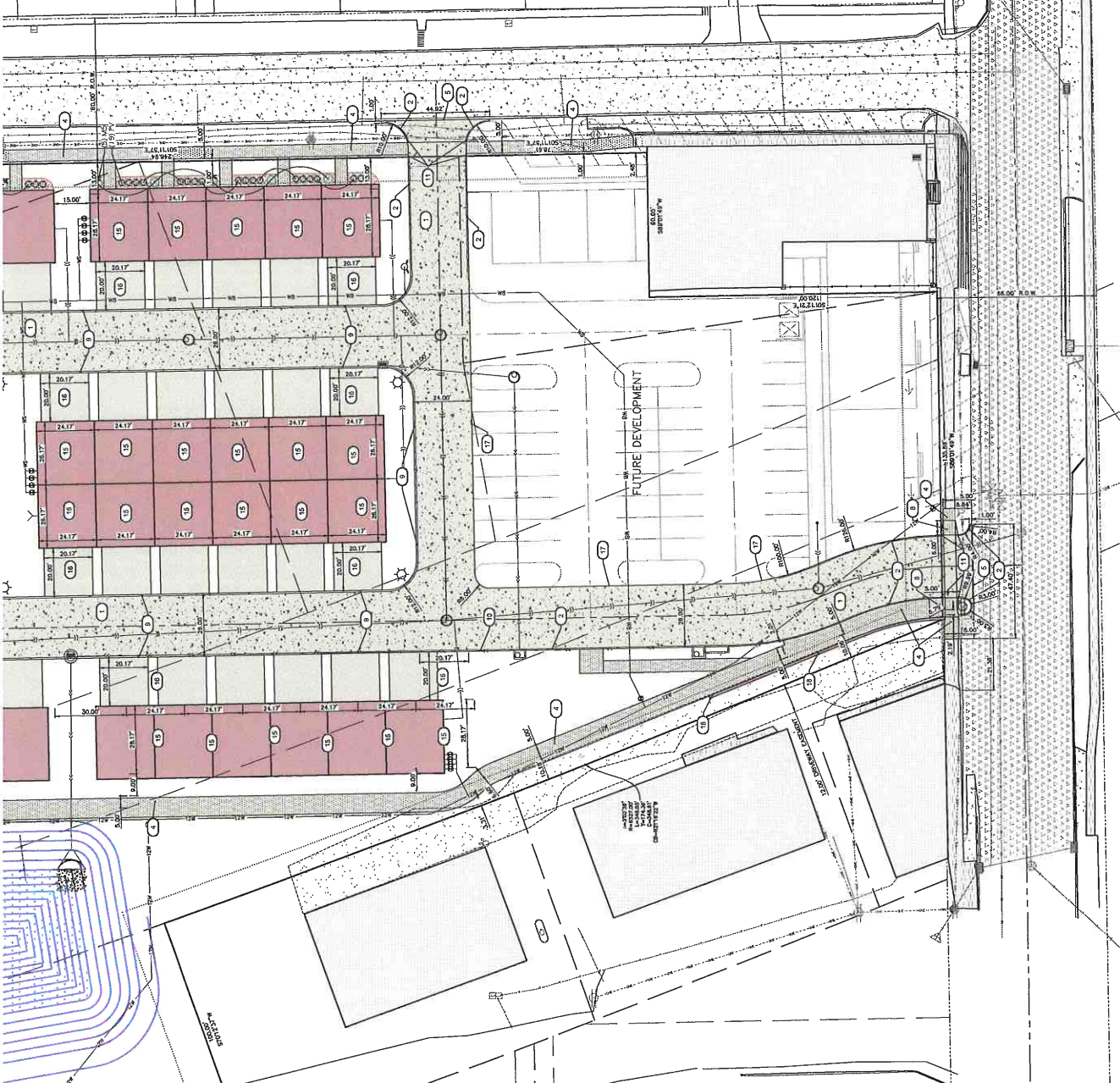

DETAILED SITE LAYOUT AND DIMENSION PLAN - SOUTH HALF

HERITAGE HILL,
LOT 1
WEST BRANCH,
CEDAR COUNTY,
IOWA

MMS CONSULTANTS, INC.
08-24-22
Designed by: JAC
Checked by: JAC
Date: 08-24-22
Project No.: C122
Sheet No.: 11186-002



CIVIL ENGINEERS
LAND PLANNERS
LAND SURVEYORS
LANDSCAPE ARCHITECTS
ENVIRONMENTAL SPECIALISTS
OWEN CITY, TENN. 37220
WWW.MMSCONSULTANTS.COM

DESIGN
INTERNAL REVIEW - A/C
PRICE

GENERAL NOTES AND DETAILS

HERITAGE HILL,
LOT 1
WEST BRANCH,
WARREN COUNTY,
TENN.

MMS CONSULTANTS, INC.
08-04-22
Designed by: R.C. Jones
Checked by: T.W. Jones
Project No.: C-500
Sheet No.: 1186-002

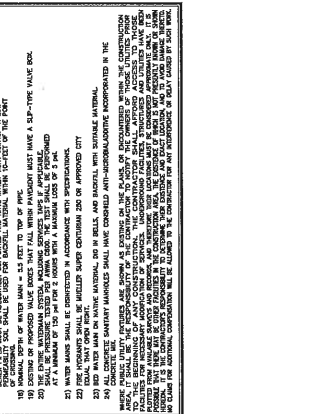
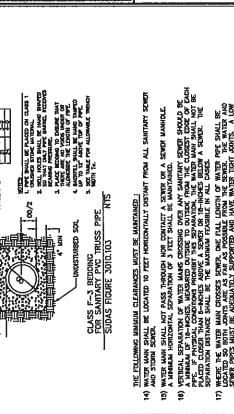
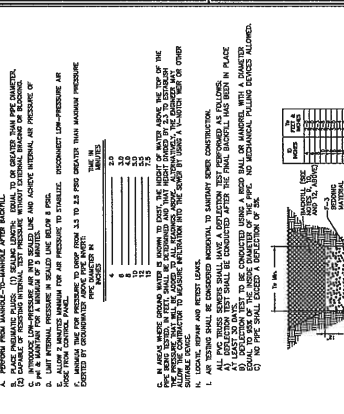
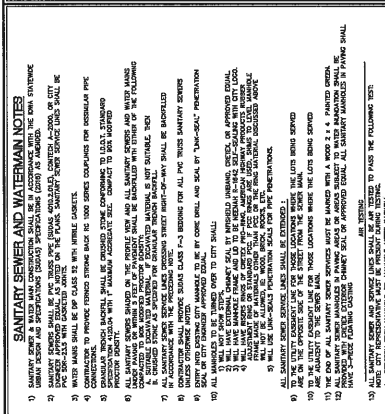
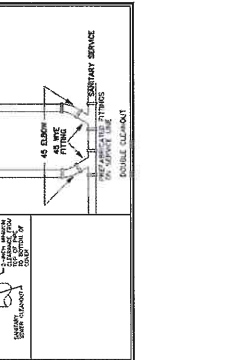
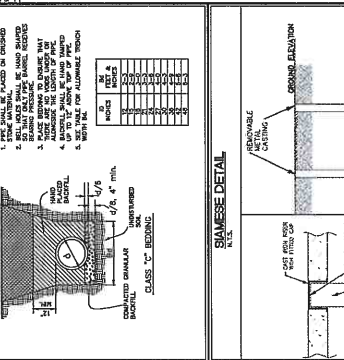
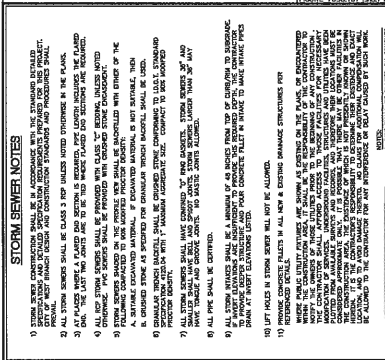
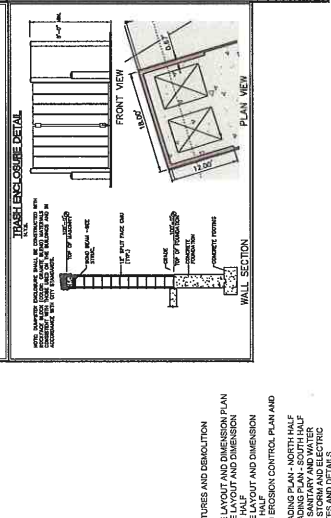
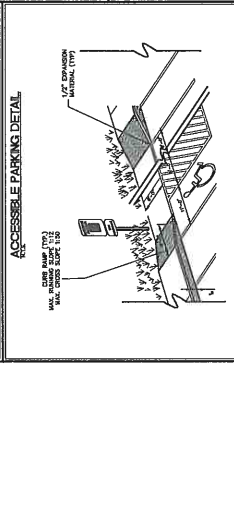
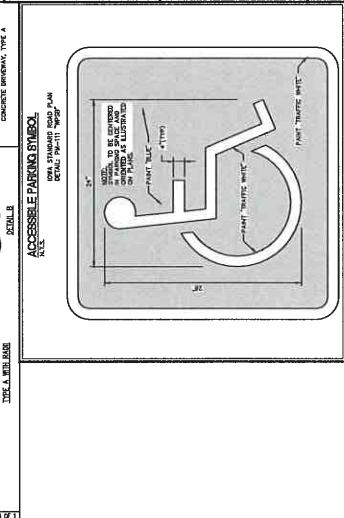
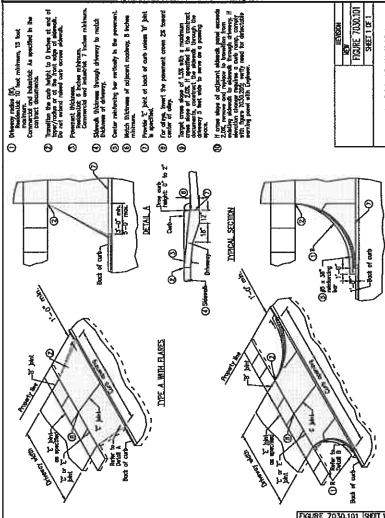
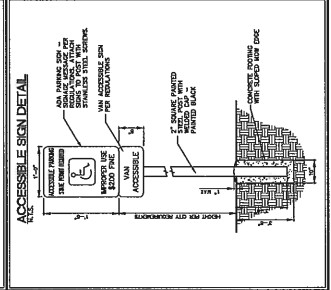
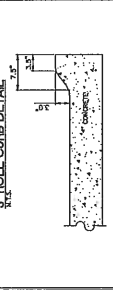
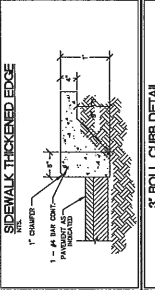
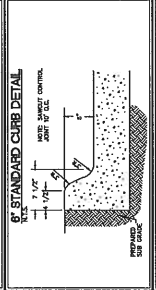
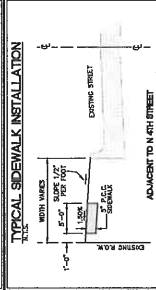
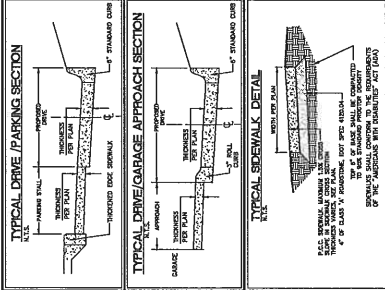

Table with 2 columns: SHEET NUMBER and DESCRIPTION. Rows include: C-500, C-501, C-502, C-503, C-504, C-505, C-506, C-507, C-508, C-509, C-510, C-511, C-512, C-513, C-514, C-515, C-516, C-517, C-518, C-519, C-520, C-521, C-522, C-523, C-524, C-525, C-526, C-527, C-528, C-529, C-530, C-531, C-532, C-533, C-534, C-535, C-536, C-537, C-538, C-539, C-540, C-541, C-542, C-543, C-544, C-545, C-546, C-547, C-548, C-549, C-550, C-551, C-552, C-553, C-554, C-555, C-556, C-557, C-558, C-559, C-560, C-561, C-562, C-563, C-564, C-565, C-566, C-567, C-568, C-569, C-570, C-571, C-572, C-573, C-574, C-575, C-576, C-577, C-578, C-579, C-580, C-581, C-582, C-583, C-584, C-585, C-586, C-587, C-588, C-589, C-590, C-591, C-592, C-593, C-594, C-595, C-596, C-597, C-598, C-599, C-600.



CIVIL ENGINEERS
LAND PLANNERS
LAND SURVEYORS
LANDSCAPE ARCHITECTS
ENVIRONMENTAL SPECIALISTS

1000 UNIVERSITY AVENUE
DOWNS CITY, IOWA 52242
PHONE: 319-382-2200
FAX: 319-382-2202
WWW.MMSCONSULTANTS.COM

Date	Revision
9/10/22	INTERNAL REVIEW *NO
9/10/22	INTERNAL REVIEW *NO

GENERAL NOTES AND DETAILS

HERITAGE HILL,
LOT 1
WEST BRANCH,
CEDAR COUNTY,
IOWA

MMS CONSULTANTS, INC.	
Project No.	08-04-22
Client	Heritage Hill
Design by	M.C.
Drawn by	J.W.
Checked by	J.W.
Approved by	J.W.
Project No.	C501
Sheet No.	11186-002

W4-4p
36" x 18"

METHOD W4-4p SIGN

A	B	C	D	E	F	G	H	J	K	L	M	N
26	12	375	692	3	235	1.6	3314	3.93	1.2	10.008	7.775	2.258
26	12	375	692	3	235	1.6	3314	3.93	1.2	10.008	7.775	2.258
36	18	692	692	4	3.5	3	14.498	14.978	2.25	15.214	12.512	3.5.5
48	24	75	125	5.5	4.5	4	18.828	19.298	3	20.214	19.58	4.5.5

COLORS: LEGEND — BLACK
BACKGROUND — YELLOW (RETROREFLECTIVE)

K-6530
36" x 36"

COLORS: LEGEND — BLACK
BACKGROUND — YELLOW (RETROREFLECTIVE)

A	B	C	D	E	F	G	H	J	K	L	M
24	375	692	692	3	2	4.893	1.8	8.767	5.844	5.278	3.15
36	692	692	692	3	3	6.245	1.8	11.611	8.686	8.448	2.25
48	75	125	175	5.25	3.522	16.378	10.898	17.692	10.567	10.047	3

- SHEET INDEX:
- C010 PLANNING FEATURES AND DEMOLITION PLAN
 - C101 DETAILED SITE LAYOUT AND DIMENSION PLAN - NORTH HALF
 - C102 DETAILED SITE LAYOUT AND DIMENSION PLAN - SOUTH HALF
 - C103 CONVEYING AND EROSION CONTROL PLAN AND SWPPP
 - C104 DETAILED GRADING PLAN - NORTH HALF
 - C105 DETAILED GRADING PLAN - SOUTH HALF
 - C106 UTILITY PLAN - SANITARY AND WATER
 - C107 LANDSCAPE PLAN - SANITARY AND WATER
 - C200 GENERAL NOTES AND DETAILS
 - C501 GENERAL NOTES AND DETAILS
 - C502 LANDSCAPE PLAN

